

15. What if my VFD is equipped with a by-pass?

On Variable Frequency Drive (VFD) installations designed or specified with a bypass circuit, it is recommended that the LINEATOR™ AUHF be installed within the bypass circuit as shown in Figure 15-1.

When the LINEATOR™ is left in the circuit with the VFD bypassed, its through impedance will cause a voltage drop at the motor. This typically will not be enough to under excite or completely ‘starve the motor of voltage’ but will cause the motor to draw more current to compensate for the lower voltage. This could lead to slightly higher slip, heavier losses, lower torque and the potential for overheating. If it is determined that the motor can accept the voltage drop, then the LINEATOR can be left in the circuit when the VFD is being by-passed.

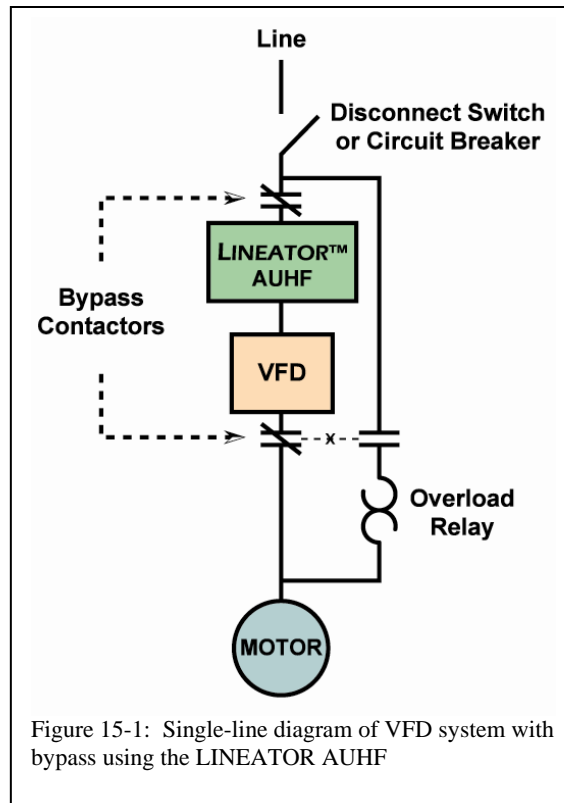

16. Can I use a single LINEATOR to supply multiple VFD's?

A single LINEATOR™ can be used to supply multiple VFD's but in such an application all downstream loads must be VFD's. The trapezoidal output voltage of the LINEATOR™, although ideal for a VFD application, is not suitable for fixed speed motors or other linear loads.